

## **Chapter 242. STREETS AND SIDEWALKS**

[HISTORY: Adopted by the Board of Commissioners of the City of Margate City as indicated in article histories. Amendments noted where applicable.]

### GENERAL REFERENCES

Brush, grass and weeds — See Ch. [87](#).

Cats — See Ch. [107](#).

Curbing of dogs — See Ch. [122](#).

Motorbikes and motorcycles — See Ch. [188](#).

Peddling and soliciting — See Ch. [212](#).

Property maintenance — See Ch. [215](#).

Shopping carts — See Ch. [229](#).

Towing — See Ch. [248](#).

Vehicles and traffic — See Ch. [257](#).

Police-public towing — See Ch. [275](#).

Street vacation ordinances — See Ch. [A290](#).

[242a images](#) 

## **Article I. Sidewalk Maintenance**

[Adopted 7-22-1976 as Art. II of Ch. 150 of the 1976 Code<sup>[1]</sup>]

[1]:

Editor's Note: Article [II](#) of Ch. 150 of the 1976 Code was originally derived from Ord. No. 141, adopted 6-28-1923, as amended.

### **§ 242-1. Responsibility of owners or tenants.**

All sidewalks in said City shall be kept free and clear of all snow, ice, tall grass, weeds, bushes or other impediments by the owner or owners, tenant or tenants in lands abutting or bordering upon sidewalks.

### **§ 242-2. Time limit for removal of snow and ice; performance of work by City.**

If the property owner or tenants shall fail to remove all snow and ice within 12 hours of daylight after the same shall be formed or fall thereon, the City will remove the same at the expense of owner.

### **§ 242-3. Removal of vegetation and impediments.**

In cases where the owner or owners, tenant or tenants shall have refused or neglected to remove all tall grass, weeds, bushes or other impediments within three days after notice to remove the same has been served upon the owner or owners, tenant or tenants personally where the land is occupied, or upon the owner or owners by registered mail at the last known address where the land is unoccupied or in case the owner or his address is unknown by posting said notice upon

said land, the City may cause the same to be removed under the direction of an officer of the City.

#### **§ 242-4. Costs to become lien.**

Such officer shall certify the cost thereof to the Board of Commissioners, which shall examine the certificate and, if found correct, shall cause the cost as shown thereon to be charged against the lands abutting or bordering said sidewalks. The amount so charged shall be filed in the office of the Tax Collector, shall become a lien upon such land and shall be added to and become and form part of the tax next to be assessed and levied upon said lands. The same shall bear interest at the same rate as taxes and shall be collected and enforced by the same office and in the same manner as taxes.

#### **§ 242-5. Violations and penalties.**

[Amended 1-25-1988 by Ord. No. 1988-1]

Any person violating the terms of this article shall, upon conviction thereof, be subject to a fine of not to exceed \$1,000 or to imprisonment for not more than 90 days, or to both.

## **Article II. Construction and Repair of Curbs and Sidewalks**

[Adopted 7-22-1976 as Art. III of Ch. 150 of the 1976 Code<sup>[1]</sup>]

[1]:

Editor's Note: Article [III](#) of Ch. 150 of the 1976 Code was originally derived from Ord. No. 226, adopted 12-11-1927.

#### **§ 242-6. Construction or reconstruction required.**

All the sidewalks in all the streets, roads and highways of the City of Margate City, New Jersey, shall be constructed, reconstructed, paved, repaved, curbed and recurbed, improved or repaired at the cost and expense of the owner or owners of the land in front of which any such improvements shall be made, whenever said sidewalks have not heretofore been paved or curbed or whenever required in the discretion of the Board of Commissioners of Margate City and whenever any of said sidewalks shall need reconstructing, repaving, recurbing or repairing.

#### **§ 242-7. Sidewalk specifications.**

[Amended 1-25-1988 by Ord. No. 1988-1]

The sidewalks shall be constructed, reconstructed, paved, repaved, improved or repaired to a width of not less than five feet and a depth of not less than four inches. Said sidewalks shall be constructed, reconstructed, paved, repaved, improved or repaired in accordance with the specifications of the City Engineer.

#### **§ 242-8. Curbing specifications.**

[Amended 10-8-1998 by Ord. No. 1998-20]

A.

Said sidewalks shall be curbed with concrete. Said curb shall be six inches by eight inches by 18 inches in size. See construction detail at the end of this chapter.

B.

Should the City of Margate City construct said curbs or reconstruct said curbs upon the failure of the property owner to do so, said curbs shall not be constructed or reconstructed of granite or bluestone.

**§ 242-8.1. Gutter specifications.**

[Added 10-8-1998 by Ord. No. 1998-20]

A.

Gutters shall be constructed, reconstructed improved or repaired to a depth of eight inches. Said gutter shall be constructed, reconstructed, improved or repaired in accordance with the specifications of the City Engineer. See detail at the end of this chapter.

**§ 242-9. Conformance with grade required.**

Said sidewalks shall be constructed, reconstructed, paved, repaved, curbed, recurbed, improved or repaired to conform, as nearly as practicable, to the grade of the street, road or highway, or the section thereof along which any such improvement is proposed to be made, where said grade has been established by law previous to the passage of this article.

**§ 242-10. Costs to be responsibility of owner.**

Said sidewalks shall be constructed, reconstructed, paved, repaved, curbed, recurbed, improved or repaired at the cost and expense of the owner or owners of the land in front of which such improvements shall be made.

**§ 242-11. Notice of contemplated improvement.**

Before proceeding to make any such improvements or awarding any contract for the making thereof, the Board of Commissioners of the City of Margate City shall cause notice of such contemplated improvement to be given to the owner or owners of any lands affected thereby. Such notice shall contain the description of the property affected, sufficiently definite in terms to identify the same, as well as a description of the required improvements and a notice that unless said improvements shall be completed within 30 days after the service thereof, it is the intention of the City of Margate City to make such improvement or cause the same to be done pursuant to the authority of Chapter 152, Laws of 1917, as amended and supplemented.<sup>[1]</sup>

[1]:

Editor's Note: See Title 40, Municipalities and Counties, of the New Jersey Statutes, Subtitle 3, Municipalities Generally. Specific provisions as to sidewalks are found in N.J.S.A. 40:65-1 et seq.

**Article III. Sidewalk Obstructions**

[Adopted 7-22-1976 as Art. IV of Ch. 150 of the 1976 Code<sup>[1]</sup>]

[1]:

Editor's Note: Article [IV](#) of Ch. 150 of the 1976 Code was originally derived from Ord. No. 441, adopted 8-21-1947, as amended.

### **[§ 242-12. Obstructions prohibited.](#)**

No merchandise, material, boxes, stands, magazines, newspapers, produce, fruits, vegetables, advertising signs or any object or obstruction shall be placed, maintained or permitted upon any part of any public sidewalk within the limits of the City of Margate City, New Jersey, except United States mailboxes. Said sidewalks shall remain free and clear of all obstructions for the use of pedestrians.

#### **[A.](#)**

Certain displays in the public right-of-way, in front of stores located within the commercial retail districts, shall be permitted to assist the merchants to market their merchandise and goods on specific dates and times approved by the Board of Commissioners. The dates and times to display merchandise in the public right-of-way shall be known as "sidewalk sales days." No merchandise may be displayed in the public right-of-way on non-sidewalk-sales days.

[Added 4-7-2011 by Ord. No. 7-2011]

#### **[B.](#)**

Merchandise, inventory and goods, which are offered for sale within a store, may be displayed in front of the exterior storefront within the public right-of-way in the commercial retail districts on the approved dates and times.

[Added 4-7-2011 by Ord. No. 7-2011]

#### **[C.](#)**

Merchandise displayed within the public right-of-way must not occupy more than the merchant's storefront width. Merchants may not use any portion of contiguous property owners' property to display merchandise. The display shall not obstruct the storefront entrance. The top of the display shall not be higher than eight feet above the sidewalk surface. The merchandise may be displayed under a tent, provided the size and dimensions of the tent are approved by the Zoning Officer and Code Official. The Zoning Officer shall ensure that there are no visual obstructions to neighboring businesses or general safety issues relative to the use of tents. The Construction Official shall ensure there are no fire safety issues relative to the use of tents.

[Added 4-7-2011 by Ord. No. 7-2011]

#### **[D.](#)**

Merchandise displayed within the public right-of-way must not obstruct pedestrian traffic. A minimum of three feet must be maintained for pedestrian traffic to pass unobstructed in front of the storefront displaying merchandise in the public right-of-way.

[Added 4-7-2011 by Ord. No. 7-2011]

#### **[E.](#)**

Merchandise displayed within the public right-of-way must be displayed in a visually appealing manner. The Zoning Officer shall make the final determination regarding the visual attractiveness of the display. The display must be removed if it is not approved by the Zoning Officer. Merchandise may not be attached to trees or utility poles. All merchandise must be removed at the end of each sidewalk sale day and placed indoors or off the public right-of-way.

Temporary supports to display merchandise, such as racks, tables, carts and shelves must also be removed at the end of each sidewalk sale day and placed indoors or off the public right-of-way.  
[Added 4-7-2011 by Ord. No. 7-2011]

F.

No merchandise may be displayed in the public right-of-way in front of any store in the commercial business districts except as provided above.  
[Added 4-7-2011 by Ord. No. 7-2011]

**§ 242-13. Violations and penalties.**

A.

Any person violating the provisions of this article shall, upon conviction thereof, be subject to a fine not exceeding \$1,000 or imprisonment not exceeding 90 days, or both, at the discretion of the Judge hearing the same.

[Amended 1-25-1988 by Ord. No. 1988-1]

B.

Each and every day that such violation occurs shall be considered a separate and specific violation of this article and not a continuing offense.

**Article IV. Excavations and Openings**

[Adopted 7-22-1976 as Art. V of Ch. 150 of the 1976 Code<sup>[1]</sup>]

[1]:

Editor's Note: Article V of Ch. 150 of the 1976 Code was originally derived from Ord. No. 872, adopted 4-26-1973, as amended.

**§ 242-14. Permit required.**

It shall be unlawful to dig, excavate, open or in any manner interfere with or disturb the surface of any street or sidewalk area within the City of Margate City for any purpose whatsoever without first securing a permit therefor as hereinafter provided.

**§ 242-15. Application; fee.**

[Amended 10-8-1998 by Ord. No. 1998-20]

A.

Application for permission to make an excavation in any street between the curblines, driveways or in any sidewalk area shall be made to the City Engineer. Such application shall be made on the required application form and shall be signed by the applicant and shall specify:

(1)

The applicant's name, address and phone number. (local and out-of-town).

(2)

The name, address and phone number of the person or firm who will be performing the work.

(3)

The length and width of such excavation.

(4)

The purpose for which the excavation is to be made.

(5)

The estimated time required to complete the work and restore the surface.

(6)

Such other information as may be prescribed by the City Engineer.

B.

A fee of \$200 shall be paid to the City Clerk, care of the Engineer, prior to the issuance of the permit for all excavations of less than six square yards. If said opened, disturbed or undermined area exceeds six square yards, the additional yardage shall be classified as "excess yardage," and an additional fee shall be due and payable by the applicant for all yardage in excess of six square yards at a rate of \$10 per square yard.

C.

The area opened, disturbed or undermined by the applicant shall be measured and determined by the office of the Engineer.

#### **§ 242-16. Issuance of permit.**

[Amended 11-25-1992 by Ord. No. 1992-21; 10-8-1998 by Ord. No. 1998-20]

The Engineer, upon receipt and examination of the application and the fee referred to hereinabove, shall issue a permit under his hand for the excavation. He shall specify on the permit that it is good for a thirty-day period from date of issuance. He shall further specify on the permit that such work shall be completed and the road or sidewalk surface restored within 48 hours after work is commenced or within a duration of time which in his opinion is reasonable and fair. The applicant shall notify the Engineer 28 hours before the commencement of any work so that appropriate inspections can be made where required.

#### **§ 242-17. Restoration of excavated area.**

[Amended 8-11-1988 by Ord. No. 1988-15; 11-25-1992 by Ord. No. 1992-21; 9-23-1993 by Ord. No. 1993-18; 10-8-1998 by Ord. No. 1998-20]

A.

The applicant to whom such permit is issued shall, within the time limited in such permit, replace the earth and pavement in the excavation in such manner that the same shall be left in as good a condition as it was before the excavation was commenced.

(1)

Trenches shall be backfilled in layers not to exceed six inches and a vibratory tamper must be used. Ninety-five-percent compaction shall be required. Puddling of backfill is strictly prohibited. Should there be a deficiency, additional backfill material shall be supplied by the permittee. Whenever the City Engineer shall deem the material unsatisfactory for backfill, the permittee shall provide acceptable material for the backfill.

(2)

Roadways with a concrete base shall be restored using a combination of concrete and asphalt. The amount of concrete and asphalt to be used at each such excavation shall be as directed by the City Engineer. See detail at the end of this chapter.

(3)

Bituminous concrete street restoration specifications.

[\(a\)](#)

Gravel. Gravel shall be installed six inches thick. The gravel shall consist of compact soil aggregate, Type I-5. The use of a recycled asphalt product (RAP) or recycled concrete product may be substituted for the soil aggregate as long as it meets the New Jersey Department of Transportation (NJDOT) requirements for I-5 materials. The City Engineer may, at his discretion, submit samples of the soil aggregate for a gradation analysis, with the cost of said analysis to be borne by the applicant.

[\(b\)](#)

Temporary restoration.

[\[1\]](#)

Asphalt roadways.

[\[a\]](#)

Less than 100 square feet.

[\[i\]](#)

For openings in asphalt roadways that are less than 100 square feet, the temporary restoration will consist of the installation of six inches of soil aggregate, Type I-5, to a level of six inches below the level of the adjacent paved surfaces. A four-inch lift of stabilized base course, Mix I-2, followed by a two-inch lift of a bituminous concrete cold patch installed to grade.

[\[ii\]](#)

These temporary surfaces shall be left in place for a period of not less than 45 days to allow sufficient settlement to occur. Should settlement continue to be inadequate, the City Engineer shall determine when the work is acceptable for final restoration. The permittee shall be responsible for all maintenance deemed necessary by the City Engineer until such time as the final restoration is completed, which shall be completed within not more than 90 days from the date of opening.

[Amended 12-10-1998 by Ord. No. 1998-27]

[\[b\]](#)

Greater than 100 square feet.

[\[i\]](#)

For openings in asphalt roadways that are greater than 100 square feet, the temporary restoration will consist of the installation of six inches of soil aggregate, Type I-5, to a level six inches below the level of the adjacent paved surfaces. A six-inch lift of stabilized base course, Mix I-2, shall then be installed to grade.

[\[ii\]](#)

These temporary surfaces shall be left in place for a period of not less than 45 days to allow sufficient settlement to occur. Should settlement continue to be inadequate, the City Engineer shall determine when the work is acceptable for final restoration. The permittee shall be responsible for all maintenance deemed necessary by the City Engineer until such time as the final restoration is completed, which shall be completed within not more than 90 days from the date of opening.

[Amended 12-10-1998 by Ord. No. 1998-27]

[\(c\)](#)

Final restoration.

[\[1\]](#)

Asphalt roadways.

[\[a\]](#)

Less than 100 square feet. For openings less than 100 square feet, the final restoration will involve the removal of the top two inches of bituminous concrete cold patch. All edges shall be saw cut six inches beyond the actual trench width disturbed to produce a clean edge, and said edges shall be prepared with an asphaltic tack coat. A two-inch lift of bituminous concrete surface course, Mix I-5, shall then be placed to a level even with the existing road grade.

[\[b\]](#)

Greater than 100 square feet.

[\[i\]](#)

For openings greater than 100 square feet, the trenches shall be milled to a depth of two inches to a distance of at least twelve inches beyond the actual trench width to produce a clean edge. All edges shall be coated with an asphaltic tack coat prior to a two-inch lift of bituminous concrete surface course, Mix I-5, being placed to a level even with the existing road grade.

[\[ii\]](#)

No surface water shall be entrapped or ponded on the resurfaced areas. If any ponding occurs, the permittee will be responsible for performing whatever remedial action is required by the City Engineer.

[\(4\)](#)

Emergency openings.

[\(a\)](#)

No permit shall be issued for any street opening which would disturb the pavement of any road having been constructed, reconstructed or overlaid until a period of five years after the completion of said construction, reconstruction or overlay, except in the event of an emergency. The five-year period as articulated herein shall be calculated from December 31 of the year in which said road was constructed, reconstructed or overlaid and run five years thereafter. In the event that any entity shall be required to open a street and/or roadway as a result of an emergency, said emergency opening shall be reviewed by the City Engineer and if said City Engineer shall determine that no such emergency existed, then the entity so opening the street and/or roadway shall have a fine imposed upon such entity in the amount of \$1,000 for the first nonemergency opening, \$5,000 for a second nonemergency opening and \$10,000 for a third nonemergency opening.

[\(b\)](#)

In the event that an emergency requires the opening of a roadway that has been resurfaced by the City during the previous five years, a full-width restoration will be required. The restoration will consist of a six-inch dense graded aggregate base course, and a six-inch bituminous stabilized base course, Mix I-2, brought to existing grade, within the excavated area. A full width curb-to-curb milling two inches in depth to extend 20 feet beyond the limit of excavations will be performed after proper settlement in the trench area. The allowable time for the settlement shall be 45 days unless otherwise directed by the City Engineer. The final surface course shall be a two-inch bituminous concrete surface course, Mix I-5. See detail at the end of this chapter.

[\(c\)](#)

In the event that an emergency requires the opening of a roadway, the entity shall first notify the Margate City Police Department of the location and cause the emergency before commencing any work.

[Added 12-10-1998 by Ord. No. 1998-27]

[\(5\)](#)



In the event in which a property owner has a hardship condition which requires a street opening permit to be issued contrary to § [242-17A\(4\)\(b\)](#) the City Commissioners may grant relief if all of the following conditions are met:

[\(a\)](#)

A letter addressed to the City Commissioner, care of City Clerk, is received detailing the hardship and necessity of opening the street in lieu of waiting the prescribed period of time.

[\(b\)](#)

Upon receipt of the letter, a public meeting date will be set for the City Commissioners to take formal action.

[\(c\)](#)

The property owner making the request shall serve a notice to all property owners within 200 feet, by certified mail, return receipt requested, or by personal hand delivery, a minimum of 10 days prior to the public meeting.

[\(d\)](#)

The property owner shall file a copy of the notice served to adjoining property owners with an affidavit of proof of delivery of notice with the City Clerk at least three days prior to the public meeting. The notice must:

[\[1\]](#)

Identify the property by street address and block and lot.

[\[2\]](#)

State the reason for the hardship.

[\[3\]](#)

State the type and size of the utility opening.

[\[4\]](#)

Advise the adjoining property owners that if they have any objections, they must advise the City Clerk, in writing, as to their objections to the proposed street opening at least three days in advance of the public meeting.

[\[5\]](#)

State the date and time of the public meeting.

[\[6\]](#)

Be approved by the City Clerk prior to mailing.

[\(e\)](#)

The City Commissioners shall consider the request at a public meeting and review all objections received, in writing. Approval or denial of the request shall be through formal adoption of a resolution.

[\(f\)](#)

A request which includes the extension of a utility main shall not be considered and will be automatically denied.

[\(g\)](#)

A request based solely on economic savings shall not be considered and will be automatically denied.

[\(6\)](#)

If more than three individual excavations would be required with a twenty-foot length, a single trench must be used rather than the individual excavations.

[\(7\)](#)

In all cases where concrete has to be removed prior to any excavation, saw cut methods of removal shall be used. The restoration of the concrete shall be according to the following specifications:

(a)

It shall be Class B with a design strength of 3,700 pounds per square inch.

(b)

It shall have a minimum thickness of not less than four inches for sidewalk, six inches for driveway aprons and eight inches for gutter.

(c)

It shall have a minimum width of not less than five feet for sidewalks.

(d)

It shall have control joints not less than five feet for sidewalk, 10 feet for curb and gutter and expansion joints not less than 20 feet for sidewalk, curb and gutter.

B.

By the acceptance of such permit, the applicant shall be deemed to have agreed to comply with the terms hereof and, upon his failure to do so, to pay on demand any cost or expense that the City may incur by reason of any shrinkage or settlement in the excavated area resulting from such excavation if such shrinkage or settlement shall occur within three months from the time the surface thereof is restored.

#### **§ 242-18. Public utility company bond; fee.**

[Amended 10-8-1998 by Ord. No. 1998-20]

Any public utility company in the City of Margate City, in the conduct of its business, shall post with the City Clerk a bond for \$10,000, which bond shall be approved by the City Attorney and conditioned to ensure the proper restoration of all streets and sidewalks opened by said utility company. The public utility company shall give written notice of all streets and sidewalks which it desires to open to the Engineer, who shall issue a permit for each project to open said street or sidewalk. Said utility shall pay to the City Clerk, care of the City Engineer, for the use of the City of Margate City the amount as indicated in § [242-15](#) of the City Code.

#### **§ 242-19. Clearance for fire equipment.**

The excavation work shall be performed and conducted so as not to interfere with access to fire stations and fire hydrants. Materials or obstructions shall not be placed within 15 feet of fireplugs. Passageways leading to fire escapes or fire-fighting equipment shall be kept free of piles of material or other obstructions.

#### **§ 242-20. Protection of traffic.**

A.

The permittee shall erect and maintain suitable timber barriers to confine the earth from trenches or other excavations so as to encroach upon highways as little as possible.

B.

The permittee shall construct and maintain adequate and safe crossings over excavations and across highways under improvement to vehicular and pedestrian traffic at all street intersections.

(1)

Vehicular crossings shall be constructed and maintained of plant, timbers and blocking of adequate size to accommodate vehicular traffic safely. Decking shall be not less than four inches thick and shall be securely fastened together with heavy wire and staples.

(2)

Pedestrian crossings shall consist of planking three inches thick, 12 inches wide and of adequate length, together with necessary blocking. The walk shall be not less than three feet in width and shall be provided with a railing, as required by the City Engineer.

#### **§ 242-21. Guarding of excavations.**

The applicant to whom a permit is granted shall keep the excavations properly guarded and shall place lights thereat at night. At all times such excavations shall be made so as to allow safe passage of pedestrians and vehicles in and along the public way.

#### **§ 242-22. Responsibility and liability of City.**

A.

The City shall not be responsible for any injury or damage to persons or property resulting from the negligence of the applicant or his servants, agents or employees in making, grading or filling any excavation permitted under the terms of this article.

B.

This article shall not be construed as imposing upon the City or any official or employee any liability or responsibility for damages to any person injured in the performance of any excavation work for which an excavation permit is issued hereunder; nor shall the City or any official or employee thereof be deemed to have assumed any such liability or responsibility by reason of inspections authorized hereunder, the issuance of any permit or the approval of any excavation work.

#### **§ 242-23. Violations and penalties.**

[Amended 1-25-1988 by Ord. No. 1988-1; 10-8-1998 by Ord. No. 1998-20]

Any person, firm or corporation violating any of the provisions of this article shall, upon conviction thereof before the Judge of the Municipal Court, be subject to a fine not exceeding \$1,000 or to imprisonment in the City or county jail for a period not exceeding to 90 days, or both. Penalties for violating the emergency road opening provisions are contained in § 242-17 of the City Code.

### **Article V. Dumping and Littering**

[Adopted 6-10-1982 as Section 2 of Ord. No. 1982-13]

#### **§ 242-24. Prohibitions.**

[Amended 4-25-1991 by Ord. No. 1991-9]

A.

No person or persons shall dump, throw or deposit any earth, building material, dirt, ashes, papers, advertising matter, boxes, rubbish, junk, vehicle parts, rubber tires, appliances, furniture or other household or commercial solid waste upon the streets, highways, sidewalks, vacant lots or other places within the City of Margate City, New Jersey, whether publicly or privately owned; provided, however, that this section shall not apply to the placing of building materials on the driveways of streets or highways when authorized by permit therefor.

B.

Distribution of handbills. It is unlawful for any person to place, to cause to be placed or to hire another person to place any advertisement, handbill or unsolicited material of any kind in or on any street, sidewalk, building, beach, vehicle or utility pole within the City of Margate City.

**§ 242-25. Deposit of offensive or putrid matter prohibited; cleaning of sidewalks.**

A.

No person shall throw, put, place or suffer his servant or employees to throw, put, place or deposit in or upon the Boardwalk or any street, highway or sidewalk in said City or upon the grounds within said City any dead animal, carrion, putrid meat, putrid fish, entrails or offal of fish or other offensive, putrid or unwholesome substances or any vegetable matter.

B.

It shall be the obligation of any person or persons, corporation, partnership or sole proprietor who is the owner, lessee, tenant, occupant or person in charge of any commercial or residential property in the City of Margate City to keep clear of any debris, trash, obstructions or nuisances of every kind the sidewalk, curb, gutter, catch basins, backyards, courts and alleys which abut said property.

[Amended 4-25-1991 by Ord. No. 1991-9]

**§ 242-26. Sweeping onto streets prohibited.**

[Added 4-25-1991 by Ord. No. 1991-9<sup>[1]</sup>]

No person or persons who are owners, tenants, occupants or person in charge of any commercial or residential property in the City of Margate City shall be permitted to sweep into or deposit in any street, gutter, catch basin or other public place any accumulation of litter from any public or private sidewalk, driveway or alley. All litter sweepings from said places shall be collected and properly containerized for disposal.

[1]:

Editor's Note: This ordinance also redesignated former § 242-26, Violations and penalties, as § 242-28.

**§ 242-27. Littering prohibited.**

[Added 4-25-1991 by Ord. No. 1991-9]

A.

It shall be unlawful for any person to throw, drop, discard or otherwise place litter of any nature upon any public or private property, other than in a litter receptacle.

B.

As used in this section, the following terms shall have the meanings indicated:

## LITTER

Any used or unconsumed substance or waste material which has been discarded, whether made of aluminum, glass, plastic, rubber, paper or other natural or synthetic material or any combination thereof, including but not limited to any bottle, jar or can, or any top, cap or detachable tab of any bottle, jar or can, an unlighted cigarette, cigar, match or any flaming or glowing material or any garbage, trash, refuse, debris, rubbish, grass clippings or other lawn or garden waste, newspaper, magazines, glass, metal, plastic or paper containers or other packaging or construction material.

### § 242-28. Violations and penalties.

[Added 1-25-1988 by Ord. No. 1988-1; amended 4-25-1991 by Ord. No. 1991-9]

#### A.

No person or persons shall dump, throw or deposit any earth, building material, dirt, ashes, papers, advertising matter, boxes, rubbish or other articles upon the streets, Boardwalk, highways, sidewalks or other places in the City of Margate City, nor shall any person or persons deposit any of the aforementioned items on any vacant lot within the City of Margate City, New Jersey, whether publicly or privately owned; provided, however, that this section shall not apply to the placing of building materials on the driveways of streets or highways when authorized by permit therefor, and no person shall distribute any circulars or advertising matter within said City by placing on vehicles or by throwing or depositing the same upon the porches or within the yards.

#### B.

The penalty for violation of this section shall be in the amount of 100.

[Added 4-17-2014 by Ord. No. 21-2014]

# STREETS AND SIDEWALKS

242 Attachment 1

## Sidewalk Detail

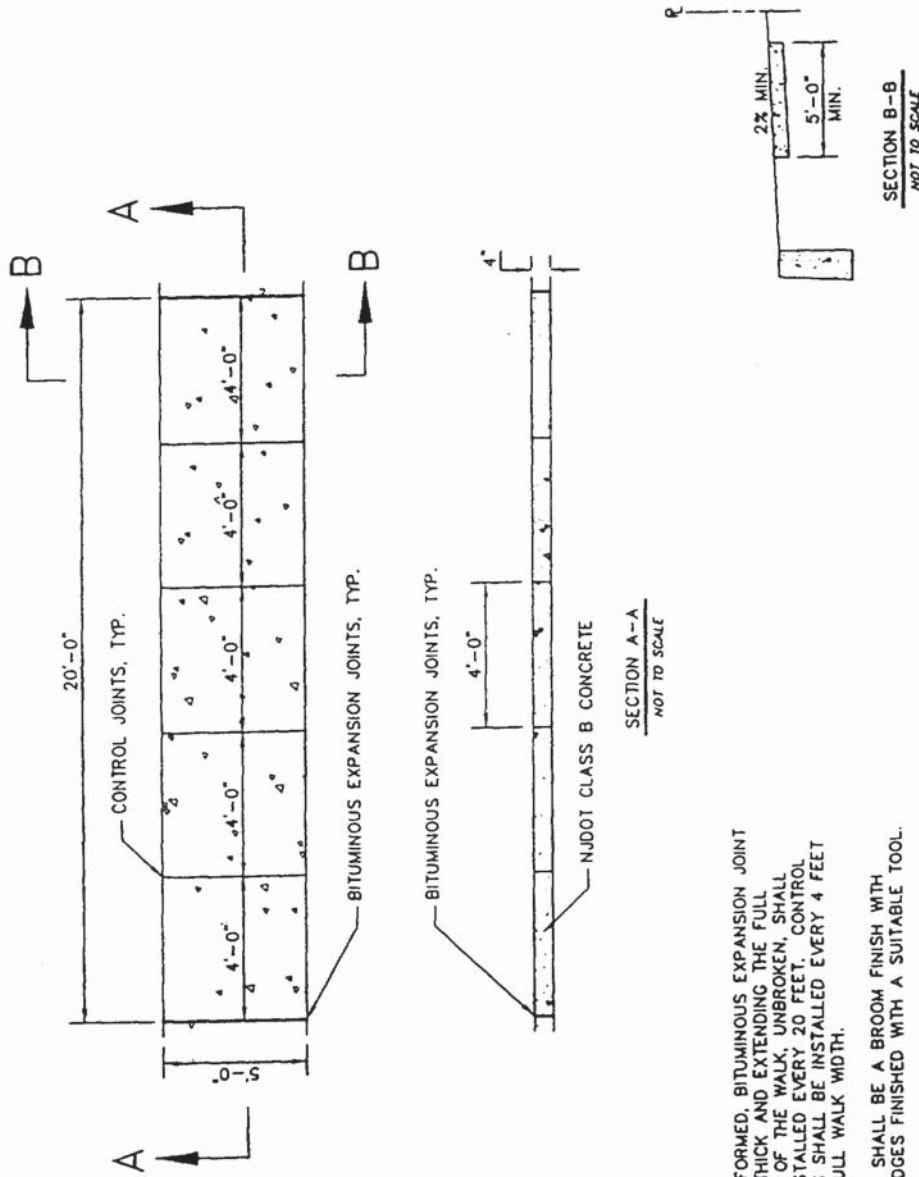

- NOTES:**
- 1.) A PREFORMED, BITUMINOUS EXPANSION JOINT 1/2" THICK AND EXTENDING THE FULL WIDTH OF THE WALK, UNBROKEN, SHALL BE INSTALLED EVERY 20 FEET. CONTROL JOINTS SHALL BE INSTALLED EVERY 4 FEET THE FULL WALK WIDTH.
  - 2.) THERE SHALL BE A BROOM FINISH WITH THE EDGES FINISHED WITH A SUITABLE TOOL.

## SIDEWALK DETAIL NOT TO SCALE

### Detail of Concrete Curb and Concrete Gutter

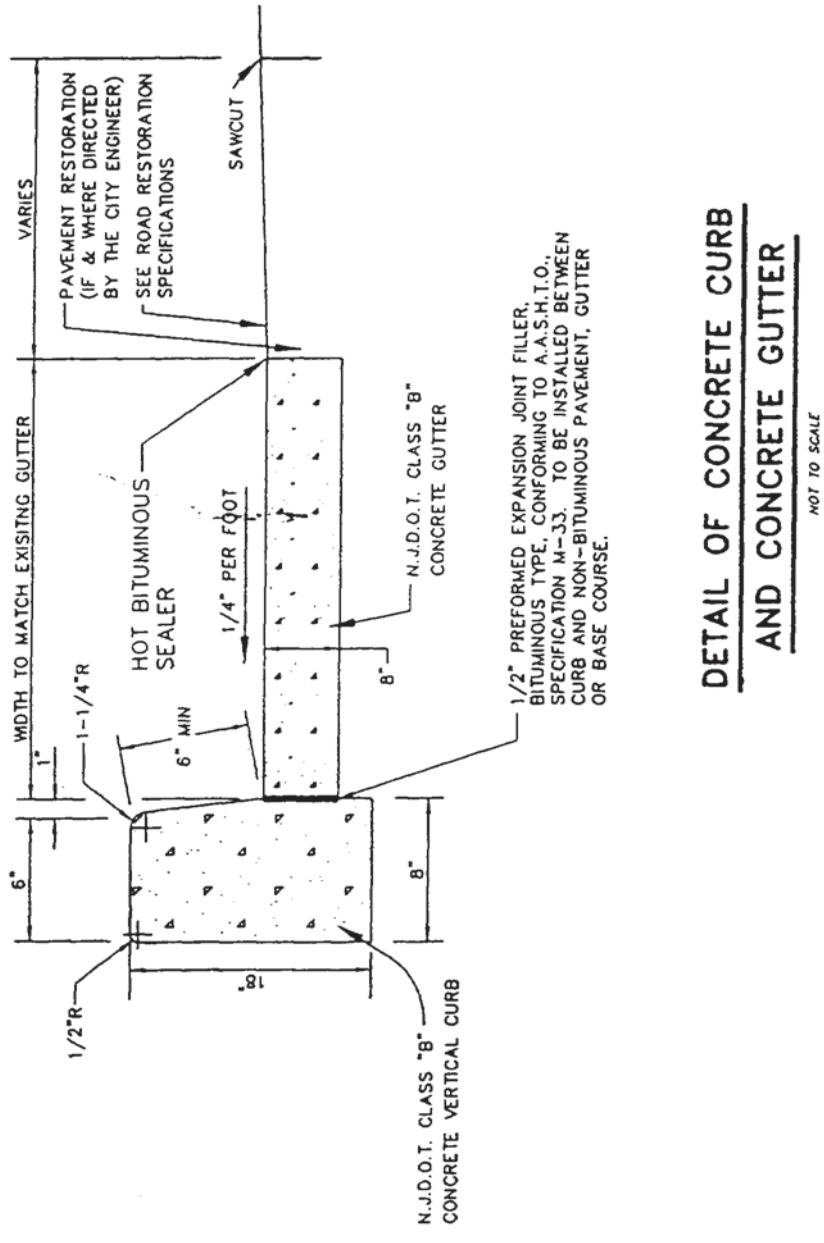

STREETS AND SIDEWALKS

Depressed Curb Detail

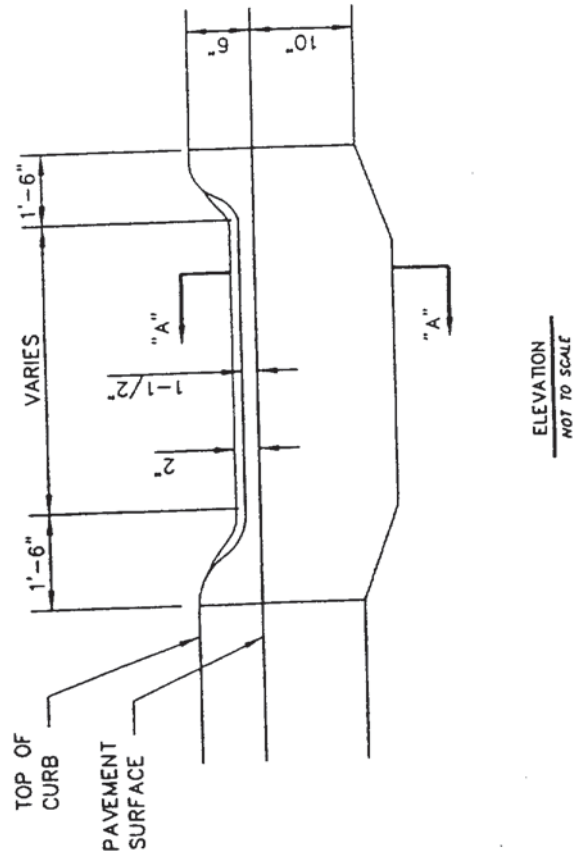
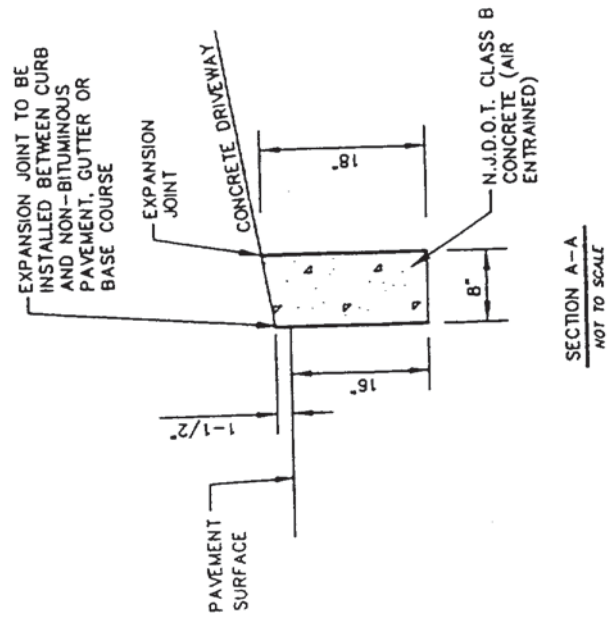

DEPRESSED CURB DETAIL  
NOT TO SCALE



### Driveway Apron and Curb Depression

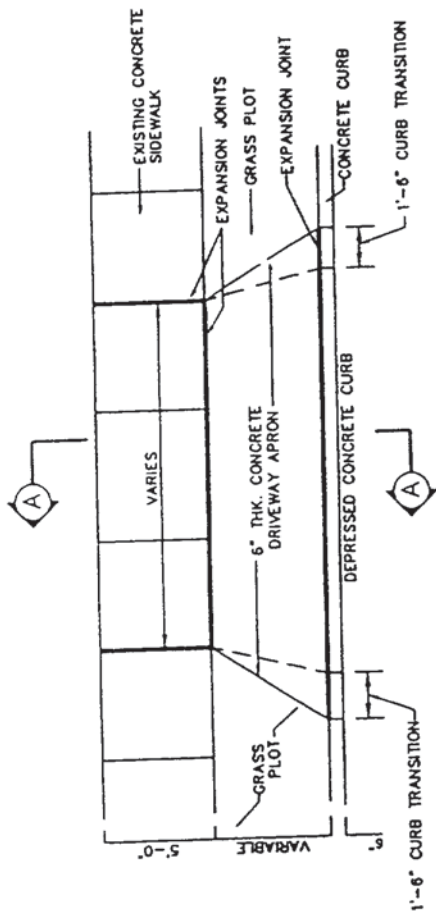

PLAN VIEW  
NOT TO SCALE

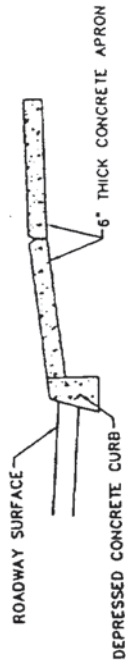

SECTION A-A  
NOT TO SCALE

### DRIVEWAY APRON & CURB DEPRESSION (APPLICABLE WITH STANDARD CURB)

NOT TO SCALE

# STREETS AND SIDEWALKS

## Street Restoration (With Existing Concrete Base Course)

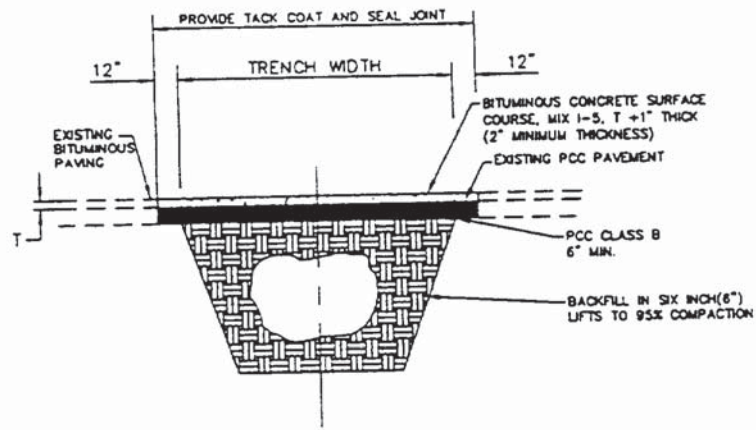

## STREET RESTORATION (WITH EXISTING CONCRETE BASE COURSE)

NOT TO SCALE

MARGATE CITY CODE

**Street Restoration  
(Greater than 100 Square Feet)**

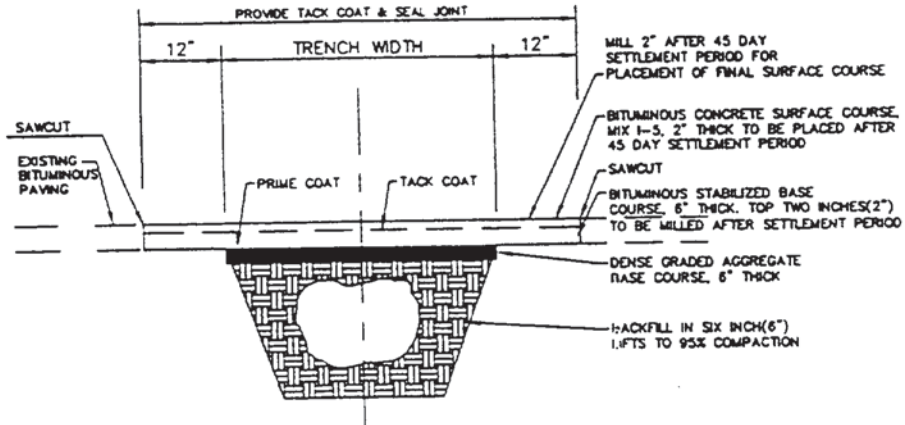

**STREET RESTORATION  
(GREATER THAN 100 SQUARE FEET)**

NOT TO SCALE

STREETS AND SIDEWALKS

**Street Restoration  
(Less than 100 Square Feet)**

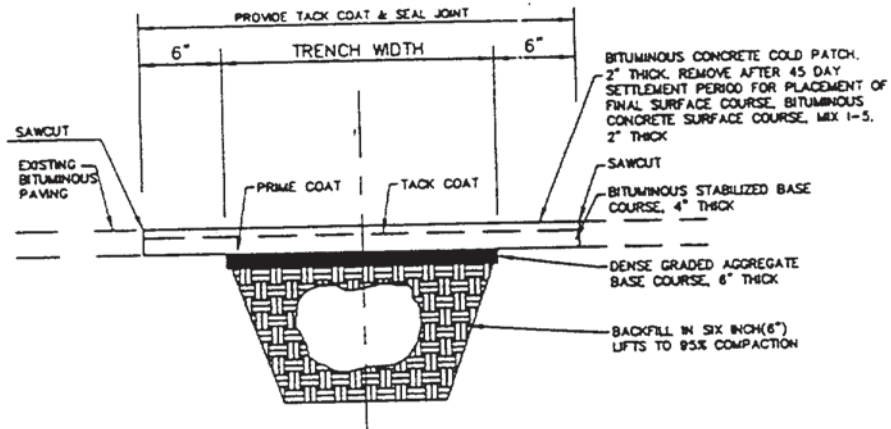

**STREET RESTORATION  
(LESS THAN 100 SQUARE FEET)**

NOT TO SCALE

### Street Restoration (Emergency Opening in Street Under Street Opening Moratorium)

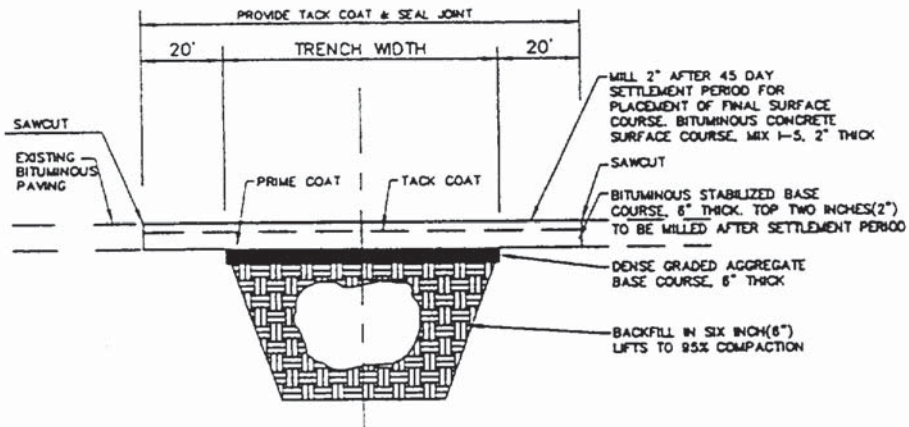

NOTE:  
RESTORATION TO BE  
CURB TO CURB

### STREET RESTORATION (EMERGENCY OPENING IN STREET UNDER STREET OPENING MORATORIUM)

NOT TO SCALE